

Convex International



*Value Stem to Boardroom Thinking*

*Past and Future Trends in the Global  
Petrochemical Industry*

May 12, 2010

Lima, Peru

BY

Arj Mukherjee

CONVEX INTERNATIONAL

Calgary, Canada

P.O. Box 67042, Northland Village P.O.,  
Calgary, Alberta, Canada T2L 2L2

Tel: (403) 208-3171

Fax: (403) 208-3177

## Outline

- *Energy Industry Dynamics*
- *Refinery - Petrochemical Integration*
- *Next Generation in Gas-Based Petrochemicals*
- *Thoughts and Concepts regarding a Petrochemical Industry in Peru*

## Energy Industry: The Universe

### Composition of Universe

Element	Abundance relative to silicon
Hydrogen	40,000
Helium	3,100
Oxygen	22
Neon	8.6
Nitrogen	6.6
Carbon	3.5
Silicon	1
Magnesium	0.91
Iron	0.6
Sulfur	0.38

### Unfortunately, the liquid state is the rarest in the Universe.

In the depths of space, matter exists as either solid (dust, meteors, asteroids) or as gas (nebulae). Liquids are always 'leaking'. In the vacuum of space there is nothing to hold a liquid together. A drop of liquid would quickly evaporate. In the rest of the Universe, the most common unit is the star. All stars are made of gas. The temperature and pressure of even the coolest star ensures that all substances within the star are gaseous.

3

## Energy Industry: Abundance of Methane on the Planet

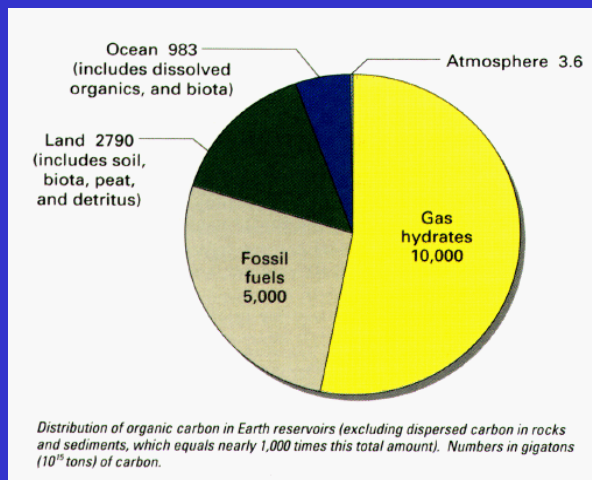

4

## Energy Industry: Extraordinary Discount of Gas to Oil

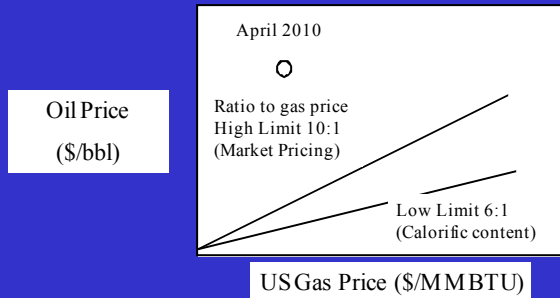

- *Non-conventional gas in the US (and globally) is having an impact on natgas pricing*
- *Supply/Demand and geopolitics is keeping oil price high*
- *Challenge is how to add maximum value to gas ?*

5

## Refinery-Petrochemicals: Adding Value to the "Crude Barrel"

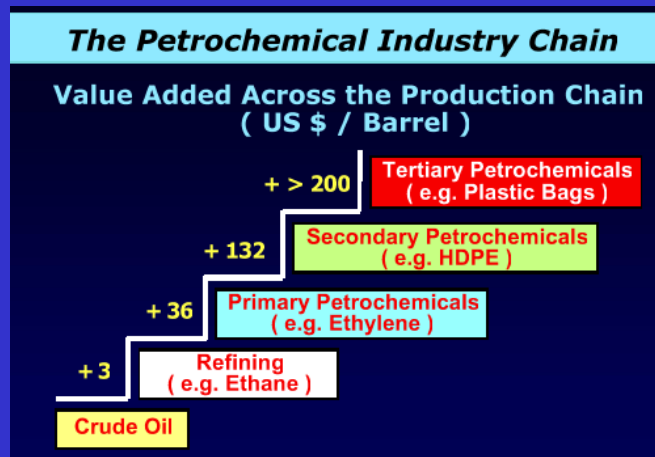

6

## Refinery-Petrochemicals: An Accelerating Trend

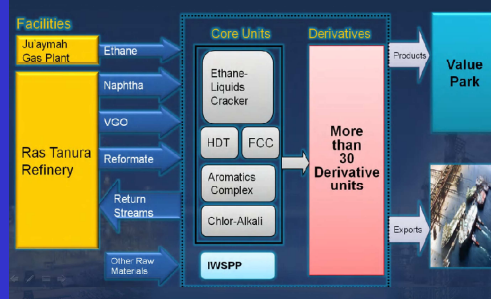

- Many sources of C2+ from associated gas, are now fully committed (Middle East)
- Heaver crude oils need upgrading
- Integrated Fuels/Petrochemicals Refining is a trend

7

## Refinery-Petrochemicals: COMPERJ Concept, Brazil

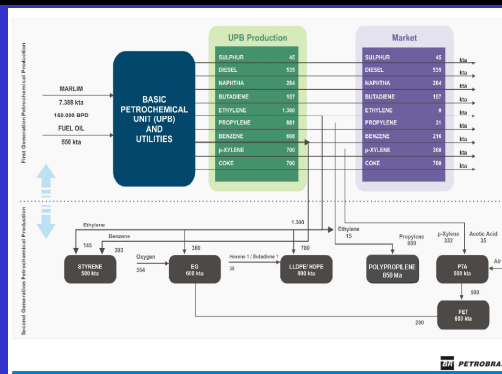

- Brazil has heavy oil production for the Campos Basin, which has to be exported at a discount
- Concept is to upgrade 150 kbpd of this heavy "Marlim" crude oil, into a balanced fuels and petrochemicals complex

8

## Refinery-Petrochemicals: Petrochemical Value Chain Concept (Brazil)

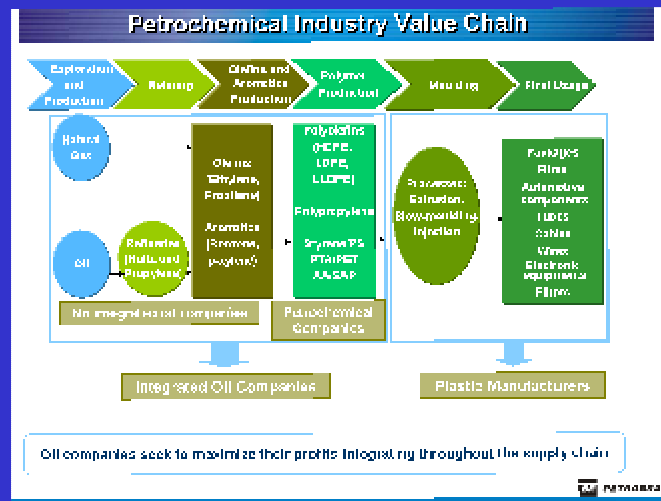

9

## Next Generation Gas Chemicals: As Strategy for Gas Monetization

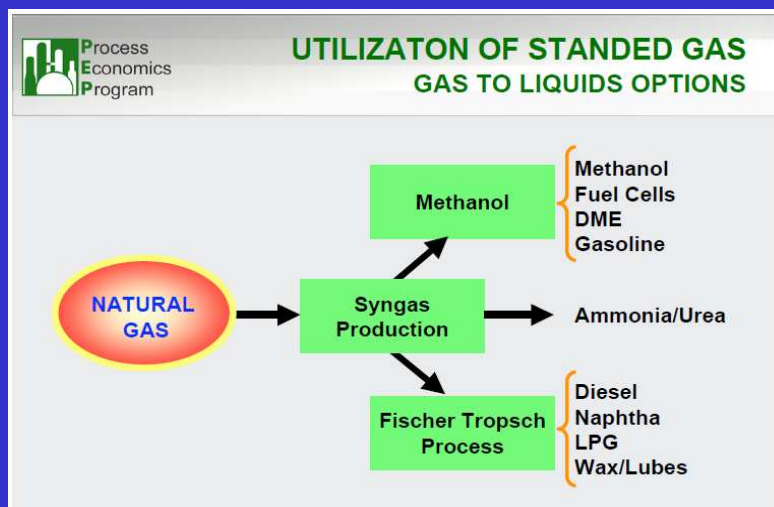

10

## Next Generation Gas Chemicals: Concept of "Methane Refinery"

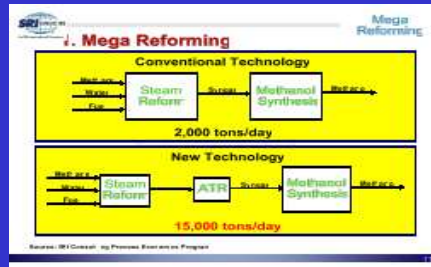
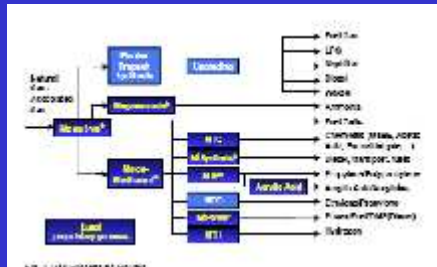

11

## Next Generation Gas Chemicals: GTL viewed as a "Petrochemical" Operation

- "First-ins" bearing brunt of risk, e.g. Sasol in Qatar; "Second-ins" stand to benefit substantially from experience curve
- Energy efficiency:
  - LNG is still substantially better than GTL, but GTL has substantial room to improve from technology evolution

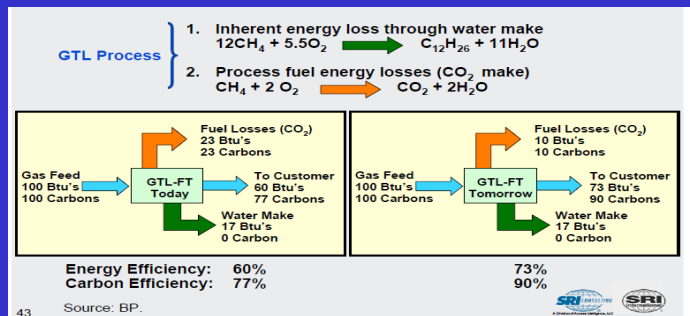

12

## Next Generation Gas Chemicals: GTL versus LNG (Capex, Opex)

- "GTL capex currently similar to LNG capex (Liquefaction+Transport+Regas)
- GTL capex and opex have more room to drop via engineering and technology improvements, LNG is more mature

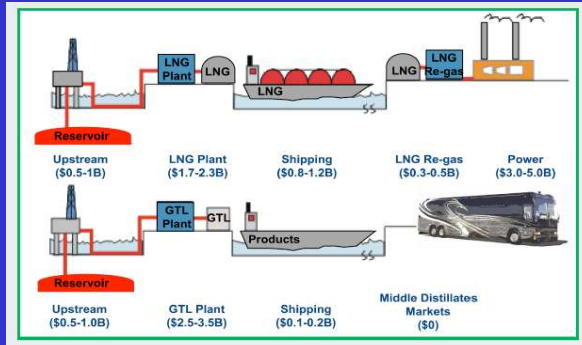

13

## Next Generation Gas Chemicals: GTL versus LNG in "Gas-Liquid" Arbitrage

- A substantial fraction of LNG commerce is done via some linkage to crude/liquids, emerging commerce to N. America via linkage to NYMEX Henry Hub gas
- "Versatility Gap" may make LNG buyers in the future reluctant to continue with price linkage to crude/refined products, causing LNG pricing to be more defined by supply economics
- GTL offers a "Pure Play" gas/liquid arbitrage, including a "Refining By-pass", and high yields of high quality distillates "Sweetspot"

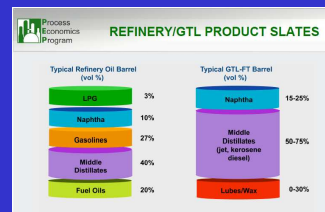
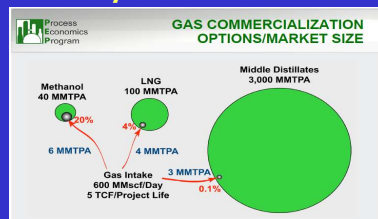

14

## Petrochemical Industry in Peru: Economic Progress

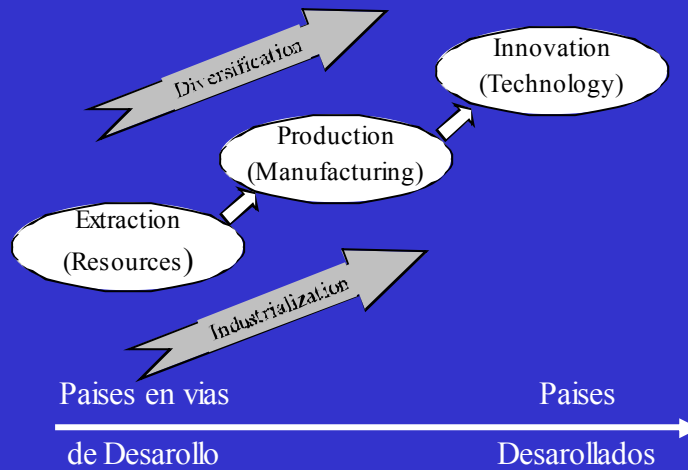

15

## Petrochemical Industry in Peru: Fertilizer Business

- *The fertilizer industry around the world is being driven by 5 major factors*
  - *Human population growth*
  - *Reduction of arable land*
  - *Increased purchasing power in emerging economies*
  - *Increase in meat consumption*
  - *Biofuels production*

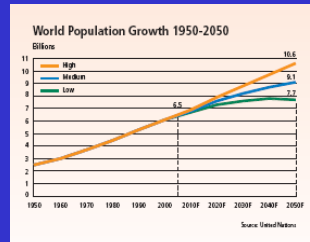
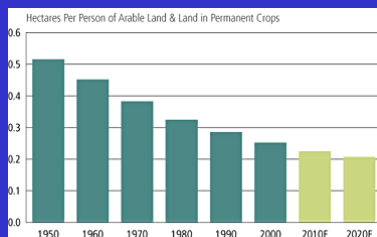

16

## Petrochemical Industry in Peru: Fertilizers for Biofuels

- Peru has arable land, but lacks water resources due to desert like coastal climate
- Desalination of seawater via thermal cogeneration can provide irrigation water, and fertilizer production can facilitate
- Brazil and the US account for most of the world's ethanol production, countries like Peru can also participate

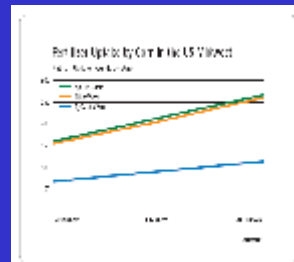
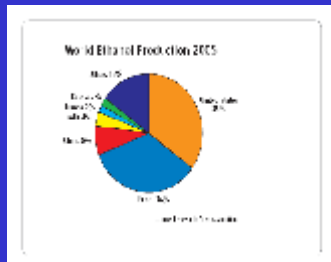

17

## Petrochemical Industry in Peru: Ethane Chemicals – High Value Materials

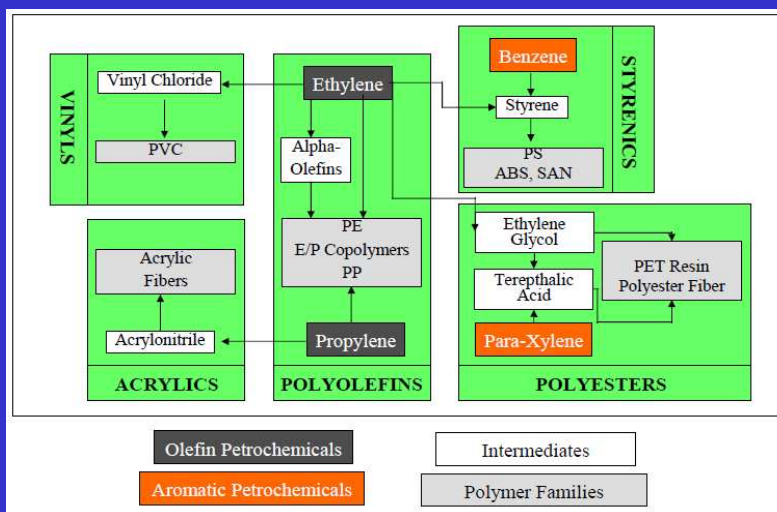

18

## Petrochemical Industry in Peru: Ethane Chemicals – Requires Government Policy

- *Alberta, Canada is home to one of the world's largest ethane chemicals industries. Alberta's experience is that the role of government is vital in enabling ethane chemicals*
- *Many competing issues relating to ethane extraction*
  - *LNG operator may wish to export Hot LNG*
  - *Pipeline operator wants maximum energy density*
  - *Power plants may have to adjust operating parameters*
- *Alberta Government since the 1970s instituted policy to promote ethane chemicals*
  - *Facilitate dialog among all impacted parties, including prospective investors*
  - *Royalty incentives for ethane extraction*
  - *Export permits for natgas, with ethane removal clauses*

19

## Petrochemical Industry in Peru: Impact of Hot LNG on Ethane Chemicals

	Existing AP LNGs		interstate pipeline gas
	lean	rich	
Methane	91.7	87.3	96.2
Ethane	6.0	8.3	1.6
Propane	1.4	3.3	0.2
Butane	0.8	1.0	0.2
Nitrogen	0.1	0.1	0.8
Carbondioxide	0.0	0.0	1.0
HHV	1100	1150	1016
Wobbe Index	1407	1435	1334
Methane Number	84	74	101

- *The table illustrates the compositions of LNG in the Asia-Pacific region, such as Malaysia, Indonesia, Australia, etc, compared to natural gas composition in US pipelines*
- *The major difference is in the concentration of ethane, as ethane is extracted for petrochemical production in North America*
- *There is a trend emerging, for ethane extraction to occur at the LNG destination rather than at the source*
- *This requires the involvement of host nations in promoting ethane value capture*

20

## Petrochemical Industry in Peru: Concept Integrated Fertilizer/Ethane Chemicals

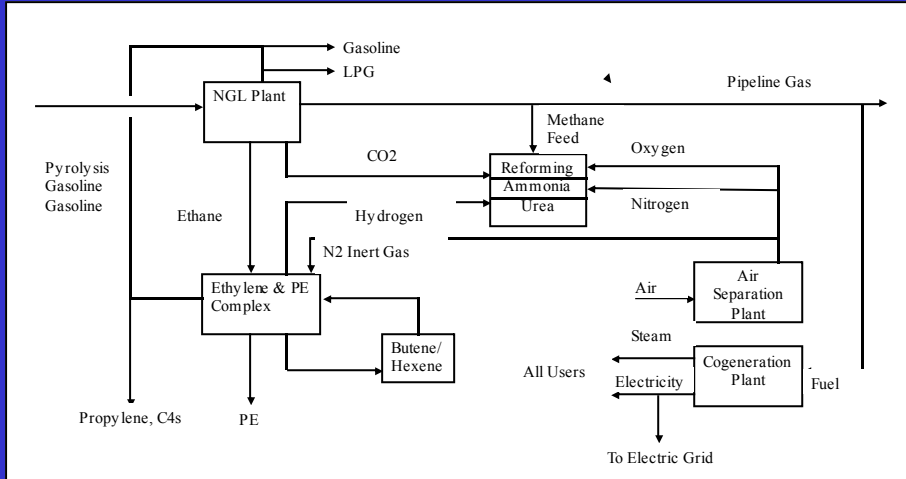

21

## Petrochemical Industry in Peru: A Vision for Economic Diversification and Integration

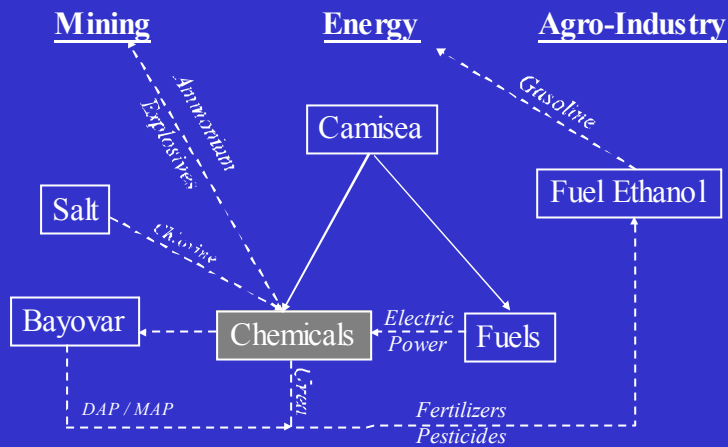

22

## Petrochemical Industry in Peru: Singapore Jurong Island Model

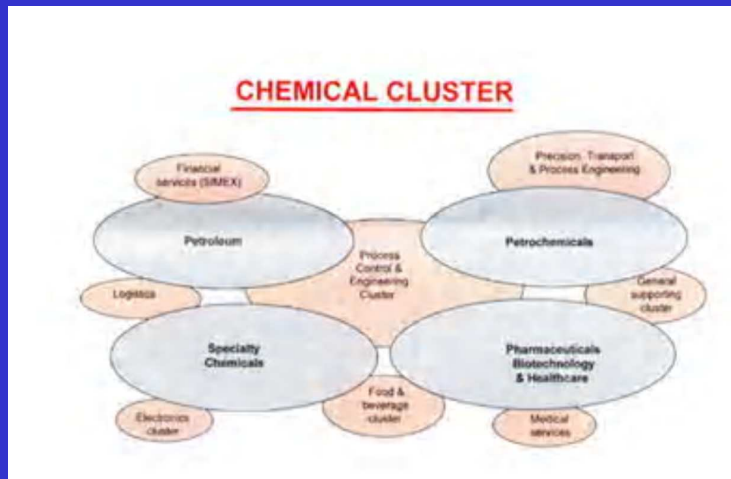

23

## Petrochemical Industry in Peru: Singapore Jurong Island Model – Features

- "Plug and play" chemicals hub model
- Service corridors, vertical integration of raw materials, intermediates, derivatives
- Utilities, logistics, power, roads, sewage, telecoms, fire station, bus services, car park, R&D park
- 2010 goal to have 150 companies, 15,000 workers, 22 million t/yr of chemicals output
- Third party providers of utilities, tankage, terminaling facilities, warehouses, ,logistics, maintenance, parts and services
- 150000 m<sup>3</sup> of water per day, via desalination via reverse osmosis using cogeneration (Singapore has a policy of water independence from Malaysia)
- They are building a new Institute of Chemical & Engineering Sciences
- A new Chemical Process Technical Centre, will train 800 technicians a year
- Jurong Island master plan evolves in conjunction with EDB of Singapore
- Jurong Island Rock Cavern has been inaugurated for crude oil storage

24

## **Petrochemical Industry in Peru: *Singapore Jurong Island Model – Aerial View***



25

## **Take Home Message: *The Future is Exciting***

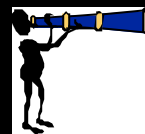

*The future presents a truly historic opportunity for Peru to harness its natural gas resources, combined with its other natural resources, human resources, and geographic/strategic position, to launch a world-class petrochemical industry, and diversify its economic base*

26